



Original Article

Impact of Innovation in Sensory Marketing on Local Brand Image, Satisfaction and Return Intention of Tourist to Ha Giang Destination

Tran Thi Lam¹, Do Thi Ngoan¹, Le Thi Tu Anh^{2,*}

¹VNUE University of Economics and Business,
No. 144, Xuan Thuy Street, Cau Giay District, Hanoi, Vietnam

²Thuongmai University, No. 79, Ho Tung Mau Road, Cau Giay District, Hanoi, Vietnam

Received: July 5, 2022

Revised: August 8, 2022; Accepted: August 25, 2022

Abstract: With the prospect that the COVID-19 epidemic will be basically controlled, many provinces and cities in Vietnam in general and Ha Giang province in particular are actively developing and implementing plans to accelerate the speed of tourism recovery, ensure safety, adapt to the new normal and aim to achieve the goal of developing the tourism industry into a spearhead economic sector. To achieve those aims, the pillar of development needs to be directed toward innovation, particularly innovation in marketing activities. This study focuses on analyzing the influence of sensory marketing on local brand image, satisfaction, and tourist retention at tourist destinations in Ha Giang province. Through data obtained from 204 tourists who have experienced Ha Giang tourism, the results show that sensory marketing through taste, sight, and touch has a direct influence on the return intention of tourists, or an influence to return indirectly through local brand image and tourist satisfaction. Therefore, the authors have proposed some solutions for stakeholders to innovate Ha Giang tourism through sensory marketing.

Keywords: Innovation, sensory marketing, local brand image, satisfaction, return intention.

1. Introduction

According to the development of the industrial revolution, the definition of productivity has also changed. Specifically,

productivity 1.0 refers to the problem of how to make employees work more and more. Productivity 2.0 refers to the problem of how to improve labor productivity by applying machines and technology; productivity 3.0 is the

* Corresponding author.

E-mail address: lehituanh@tmu.edu.vn

<https://doi.org/10.25073/2588-1108/vnueab.4863>

use of management methods to optimize productivity; and productivity 4.0 is the story of innovation.

The Ministry of Finance affirmed that the goal by 2025 is to turn the tourism industry into the spearhead economic sector of Vietnam. To achieve those aims, the pillar of development needs to be directed toward innovation, particularly innovation in marketing activities. According to the model of OECD innovation published in 2005 (OECD, 2005), innovation is measured against four types of innovation: innovation in products, innovation in processes, innovation in marketing, and innovation in organizations. In order to apply innovation in tourism, the important and practicable factors are innovation in marketing and this study analyzes innovation in sensory marketing to enhance the image of local brands and tourist satisfaction in order to drive the return intention of tourists.

In Vietnam, Ha Giang province is considered an attractive tourist destination with many unique features in nature, culture, and people, but it has not yet witnessed a remarkable change in the local economy, especially since this is still a poor province. In the 2016-2020 period, the poverty rate in the whole province was 22.29%. The rate of poor households among ethnic minorities and in remote and isolated areas is still high. To achieve the goal of sustainable poverty reduction, Ha Giang province has focused on tourism development. Sensory marketing is one of the appropriate ways to effectively promote Ha Giang's tourism, improve the image of this destination to customers, and aim to comprehensively and sustainably innovate tourism activities of the province.

Recognizing the importance of sensory marketing in enhancing the overall customer experience and the necessity of applying sensory marketing to promote tourism in Ha Giang, this paper aims to clarify the impacts of sensory marketing on local brand image and tourists' satisfaction and intention to return to Ha Giang.

2. Literature review and hypothesis development

2.1. Innovation

Innovation is the application and implementation of a new idea or a new application of an existing idea leading to a new type of product, or a new and better process for producing an existing product (Divisekera and Nguyen, 2018). According to the Oslo Handbook (OECD, 2005, p.46), innovation is defined as "the implementation of a new or significantly improved product (goods or service), process, method, new marketing, or a new organizational method in business practice, workplace organization or external relations".

The revised version of the Schumpeterian definition of innovation has a concept suitable for service industries, including tourism (OECD, 2013). Innovation in tourism shares common characteristics with innovations in any other economic sector, as well as innovations specific to the tourism industry. Service and marketing are the two main categories of innovation in the tourism industry (Kofler et al., 2018).

2.2. Sensory marketing

Sensory marketing refers to any marketing strategy that engages the consumers' senses to influence their perceptions, judgment, and situational behavior (Petit et al., 2019). Designed to appeal to one of the five senses - sight, smell, sound, touch, and taste or a combination of them - sensory marketing is a creative endeavor (Woo-Hyuk Kim et al., 2020). In other words, to become a first-rate business, it is essential to establish a sensory marketing strategy that can capture consumers' emotions. According to Jang and Lee (2019), sensory marketing is a marketing strategy that stimulates consumer emotions instead of their rational judgment by appealing to the five human senses - "sight," "smell," "sound," "taste," and "touch".

Visual marketing (sight) involves the use of images to impress the brand's identity and create a memorable visual experience, namely the perception of tourists about the space of a tourist

resort, dining places, etc. Olfactory marketing (smell) is a method of using scents to create a brand's identity and create memorable olfactory experiences that include tourists' perceptions of natural scents and atmospheres. Auditory (sound) marketing is concerned with using sound to create a brand identity and create memorable auditory experiences for tourists, such as: experiences of natural sounds, local music, and the impact of noise. Taste marketing (taste) is a method of using flavor to impress the brand identity and create a memorable taste experience that includes tourists' perception of the local culinary diversity and characteristics. Tactile marketing (touch) considers aspects such as people's attitudes, spatial design, and local produce.

2.3. Local brand image

Brand image involves the symbolic meaning associated with specific attributes of a brand (Jung et al., 2020). For example, a brand image for a particular firm is formed based on all the information (perception, reasoning, and belief) related to a company or product that people remember. In other words, local brand image relates to symbolic meanings related to specific attributes of the tourist destination.

Local brand image is defined as a set of perceptions built for a particular brand in the locality that tourists visit (Giao and Ngan, 2021). Local brand image is an aspect of a brand created by tourists, based on tourists' perceptions, whether rational or emotional.

2.4. Customer satisfaction

Satisfaction is a positive emotional response to the outcome of a previous experience. It can measure post-consumer satisfaction or current satisfaction (Ghorbanzadeh et al., 2021). Consumer satisfaction can be considered as the achievement of a consumption goal experienced by the consumer, which indicates whether the service meets the needs and expectations of the tourist (Jaesuk Jung et al., 2020). In other words, consumer satisfaction indicates the extent to

which consumers are consistently satisfied with a brand, helping to understand the long-term relationship between consumers and the brand.

2.5. Return intention

The concept of "intention to return" is derived from the theory of intended behavior. Theory of Planned Behavior is defined as a behavior that is expected in the future (Fishbein and Ajzen 1975). It has become an important, easy-to-understand metric for predicting social behavior (Ajzen, 1991).

In the leisure and tourism sector, "intention to return" is the tourist's consideration of the likelihood of returning to visit a place of recreation or a tourist destination. However, a tourist destination is considered a special product consisting of natural resources and cultural resources (Jang and Lee, 2019), so the intention of tourists to return to a foreign land again is often lower than normal product reuse, even if the destination satisfies all tourist needs and expectations. Tourists can choose places they have never been before in search of new experiences.

2.6. Hypothesis development

Sensory marketing seeks to provide consumers with experiences to create a beneficial brand image for the business or brand in order to stimulate positive consumer behavior. Furthermore, according to research by Nadanyiova et al. (2018), sensory stimulation will affect the tourist's short-term and long-term memory; at the same time having a positive impact on brand image. For the tourism industry in Vietnam, the tourism brand image of Vietnam in general and Ha Giang province in particular brings special sensory experiences when traveling here with many features of nature, culture and people.

Hypothesis 1a, b, c, d, e: Sensory marketing (Visual, olfactory, auditory, taste and tactile marketing) has a positive impact on local brand image.

According to previous studies, there is a positive relationship between brand image and consumer satisfaction (Mohammed, A & Rashid, B, 2018). Ryu, Han, and Kim (2008) and confirm that brand image can be an indicator of tourist satisfaction and behavioral intentions. As a result, companies are undertaking various activities to improve their brand image. A positive image formed in this way will also enhance consumer satisfaction. For the tourism industry, the local brand image is the sensory experiences of visitors that impress them when they come to a tourist destination. So in order to create visitor satisfaction, a brand image must be created. Brand is an important factor.

Hypothesis 2: Local brand image has a positive impact on tourist satisfaction

Moreira et al. (2017) examined how sensory marketing plays an important role in influencing tourist experience and intention to return. In other words, several previous studies have investigated the relationship between sensory marketing, tourist satisfaction, and attributive behavioral intentions (Rather, 2018a, 2018b; Rather et al., 2018; Shams et al., 2020). In addition, sensory experiences such as hearing, sight, touch, smell and taste for a destination are important because they are closely linked to the activities of local tourists. When tourism can optimize these experiences, it will contribute to motivating visitors to return in the future.

Hypothesis 3a, b, c, d, e: Sensory marketing (Visual, olfactory, auditory, taste and tactile marketing) has a positive impact on return intention.

Bloemer and de Ruyter (1998) suggest that tourist satisfaction is the mediator between brand image and the intention to return. According to Giao and Ngan (2021), there are 7 components of local brand image that have a positive impact on the return of domestic tourists respectively. Local brand image is an element formed in the process of visitors' research and experience with a destination. With Ha Giang tourism, the brand images of local food, traditional cuisine, and folk music are local characteristics that are to be found nowhere else. Therefore, these unique

points also contribute to increasing the intention of tourists to return.

Hypothesis 4: Local brand image has a positive impact on return intention.

Besides, according to research by Jang and Lee (2019), satisfaction also has a positive influence on the intention to return. Jang and Lee assert that tourist satisfaction is important in attracting tourists' intention to return. Therefore, in order to retain tourists, marketing activities need to focus on improving their satisfaction.

Hypothesis 5: Customer satisfaction has a positive impact on return intention

The concept of intention to return is derived from the Theory of Planned Behavior and is defined as an expected behavior in the future. Intended behavior is always accompanied by the observed behavior and once the intention is formed, then the behavior manifests itself. Based on the above theories, the authors propose a framework to analyze the relationship between sensory marketing, local brand image, tourist satisfaction and return intention of tourists as follows:

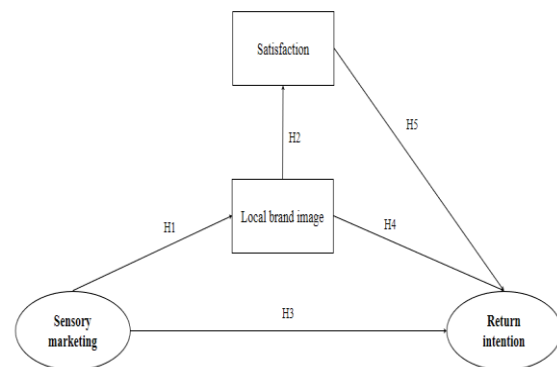

Figure 1. Analytical framework.

Source: Authors.

3. Data collection and measurement test

3.1. Data collection

According to Hair et al. (2006), Nguyen (2014), the number of suitable variables in the analysis must be at least 50, preferably 100, with

an observed/measurement ratio of 5:1, which means the measurement variable requires a minimum of 5 observations. That means the minimum required number of observations is $n = 5k$. In this research, the total number of observed variables is 34, so the minimum number of samples is 170.

The study applied the random sampling method of combined stratification according to the sampling criteria including gender, age, income, marital status, and the average number of trips per year to collect data. The survey subjects are tourists who visited Ha Giang. The data are collected by answering a questionnaire on the Google forms website for those who have experienced travel. The survey was conducted from December 2021 to January 2022. The content of the survey includes personal information of the survey respondents, and questions related to the relationship between sensory marketing, brand image, satisfaction, and intention to return for tourism in Ha Giang province.

Based on reviewing the literature to model the analytical framework, a questionnaire was built and divided into 3 sections:

The first section was designed to measure the sensory marketing activities in Ha Giang. This part comprises 24 statements in total, measuring 5 dimensions of sensory marketing: SIGHT (5 items), SMELL (4 items), SOUND (5 items), TASTE (5 items), TOUCH (4 items).

The second section aims to assess the perceived level of local brand image in Ha Giang and includes 4 items. Measuring the satisfaction level includes 5 items and the evaluation of intention to return includes 3 items.

The last section consists of questions relating to demographic information about respondents such as age, gender, income, marital status and frequency of travel.

The first two sections are measured using a 5 point Likert rating scale which corresponds to 1 = strongly disagree, 2 = somewhat disagree, 3 = neither agree nor disagree, 4 = somewhat agree,

5 = strongly agree. This questionnaire was in Vietnamese and was used to survey tourists who have been to Ha Giang so that they could give more meaningful responses. 246 potential tourists were approached and 204 feedbacks were obtained indicating a response rate of 83%. All respondents are Vietnamese. The majority of respondents are between the ages of 25 and 35, with 54.4% female, 37.7% male. Average monthly income is from 10 million to 25 million. 59.3 percent are married.

3.2. Measurement test

The data are collected by answering a questionnaire on the Google forms website for those who have experienced travel. The survey was conducted from December 2021 to January 2022. The content of the survey includes personal information of the survey respondents, and questions related to the relationship between sensory marketing, brand image, satisfaction, and intention to return for tourism in Ha Giang province.

Based on the theoretical overview and related previous studies, the research is conducted to analyze the impact of 5 sensory marketing factors (sight, smell, sound, taste, and touch) on the brand image and tourist satisfaction (intermediate variable) and then test the impact of brand image and tourist satisfaction on tourists' intention to return.

In order to analyze the data, first of all, we used exploratory factor analysis (EFA) to discover the checking structure of the sensory marketing scale. More specifically, in this stage, we removed one item after reviewing the EFA results (i.e., The hotel's music delights tourists during their meals). And then, we used confirmatory factor analysis (CFA) to test its construct validity within the sample. In addition, structural equation modeling (SEM) was used to test the proposed measurement model. The SEM model has proven efficient in many studies regarding the field of marketing management (Hair et al., 2012).

4. Data analysis

Data collected are firstly tested to ensure reliability through Cronbach's Alpha value with the purpose of checking the internal consistency. In this study, scales which have a Cronbach's Alpha coefficient greater than or equal to 0.6 will be accepted. Besides, variables which have greater than 0.3 item-total correlations will be accepted; the others which have smaller than 0.3 item-total correlations will be eliminated from the analysis data. The results of this study indicated that all Cronbach's Alpha values of the 8 dimensions ranged from 0,824 - 0.856, showing a high reliability level of the database.

Then, a validity test is conducted to measure whether the item or scale truly measures what it is supposed to measure and nothing else. In this study, a scale factor analysis is conducted for sensory marketing scales, namely SIGHT, SMELL, SOUND, TASTE, TOUCH, and local brand image scales, satisfaction scales and return intention scales. The results reveal that the questionnaire is a valid measure of the effects of sensory marketing on the local brand image in Ha Giang tourist destinations because the items which are arranged within a scale in the questionnaire are proven under the same factors.

The convergent and discriminant validity of all instruments is calculated by using AMOS 22.0. To establish convergent validity, we use

AVE or cross loadings. Convergent validity is established if the values of AVE are above 0.5 (Hair et al., 2010). From this table we can clearly see that the values of AVE for all items are 0.5 or greater than 0.5. So for the research's structure, convergent validity is established.

For analysis convergent validity, the authors examine the Average Variance Extracted (AVE). The values of AVE should be greater than 0.50, which shows that a 50% or more variance can be accounted for by these indicators (Hair et al., 2011). In this research, AVE for all latent variables is greater than 0.50.

Discriminant validity shows that one construct differs from the other construct. There are two approaches to find out the discriminant validity. One is Fornell and Larcker (1981), which says that AVE should be greater than the variance between the construct and other constructs. The second approach is that no item loading should be greater on the other construct than the construct it intends to measure (Hair et al., 2011). In other words, each construct should load higher on its assigned construct than the other constructs (Table 2). After establishing the reliability and validity of the present study through a measurement model, a structural model is calculated to find out the significance of the relationship between sensory marketing, brand image, tourist tourism and intention to return.

Table 1: Discriminant validity (Fornell-Larcker criterion)

	Min	Max	Mean	SIGHT	SAT	TASTE	SOUND	TOUCH	SMELL	IMAGE	BEI
SIGHT	2,67	5,00	4,1757	0,707							
SAT	2,60	5,00	4,2490	0,491	0,729						
TASTE	2,25	5,00	4,0319	0,425	0,478	0,74					
SOUND	1,00	5,00	4,1005	0,308	0,46	0,436	0,744				
TOUCH	2,50	5,00	3,9914	0,42	0,565	0,406	0,518	0,736			
SMELL	2,50	5,00	4,0355	0,563	0,429	0,407	0,34	0,405	0,738		
IMAGE	2,25	5,00	4,1360	0,473	0,722	0,552	0,432	0,498	0,458	0,75	
BEI	2,67	5,00	4,1879	0,414	0,674	0,507	0,387	0,428	0,346	0,681	0,793

Source: Data analysis results.

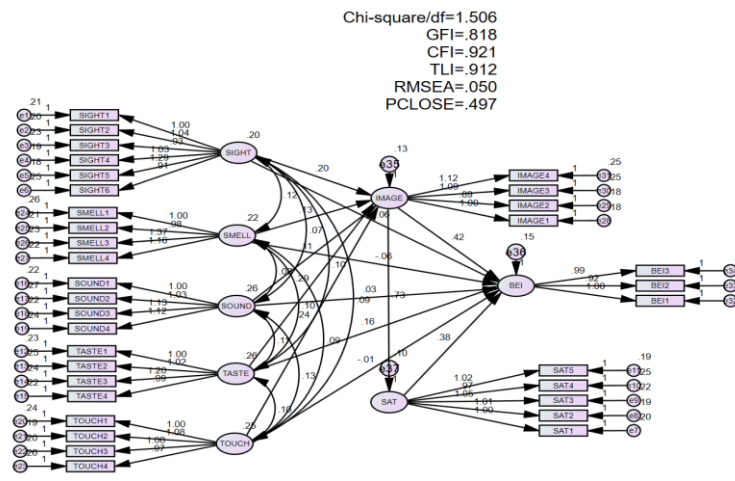

Figure 2: Relationship between structures in the model.
 Source: Data analysis results

3. Hypothesis testing

Results confirmed that the measurement structure of the theoretical framework had an acceptable fit for the data ($\chi^2/df = 1.506$, $p < .001$, $RMSEA = .050$; $CFI = .921$; $TLI = .912$). This figure organizes the results of confirmatory factor analysis, which revealed that the final measurement model fit relatively well.

The estimated results of the main parameters in the research model (Table 2) show that the relationships are statistically significant ($p < 0.05$). The results show that the hypotheses H1a, H1c, H1e, H2, H4, H5 about the relationship between the concepts proposed in the research model are accepted with statistical significance ($p < 0.05$). The rest of the hypotheses were rejected ($p > 0.05$).

Table 2: Direct relationship results

Hypothesis	Relationship	Estimate	S.E	C.R	P	Result
H1a	SIGHT → Local brand image	0.195	0.1	1.948	.050	Accept
H1b	SMELL → Local brand image	0.132	0.095	1.395	.163	Unaccept
H1c	SOUND → Local brand image	0.113	0.084	1.348	.178	Unaccept
H1d	TASTE → Local brand image	0.293	0.086	3.420	.000	Accept
H1e	TOUCH → Local brand image	0.241	0.091	2.649	.008	Accept
H2	Local brand image → Satisfaction	0.733	0.089	8.256	.000	Accept
H3a	SIGHT → Return intention	0.056	0.114	0.488	.626	Unaccept
H3b	SMELL → Return intention	-0.059	0.108	-0.543	.587	Unaccept
H3c	SOUND → Return intention	0.027	0.096	0.281	.779	Unaccept
H3d	TASTE → Return intention	0.164	0.101	1.619	.106	Unaccept
H3e	TOUCH → Return intention	-0.009	0.105	-0.082	.935	Unaccept
H4	Satisfaction → Return intention	0.424	0.175	2.428	.015	Accept
H5	Local Brand image → Return intention	0.383	0.144	2.659	.008	Accept

Source: Data analysis results.

Table 3: Indirect relationship results are accepted

Indirect relationship	Coefficient standardized	P	LLCI	ULCI
TASTE → Local brand image → Satisfaction	0.226	0.002	0.097	0.355
TOUCH → Local brand image → Satisfaction	0.182	0.033	0.044	0.335
Local brand Image → Satisfaction → Return intention	0.243	0.016	0.087	0.505
TASTE → Local brand image → Satisfaction → Return intention	0.182	0.002	0.08	0.337
TOUCH → Local brand image → Satisfaction → Return intention	0.146	0.033	0.032	0.3

Source: Data analysis results.

When we move towards mediation and take brand image and tourist satisfaction as processes or mediator variables, then the impact of sensory marketing on the intention of return is changed. It is statistically significant and positive. It means that through brand image and tourist satisfaction, the intention of return can also be enhanced. So we can say that partially brand image and tourist satisfaction mediate the relationship between sensory marketing and the intention of return. The results of indirect effects are shown in Table 3.

5. Findings and discussion

Although sensory marketing has become as important in the hotel industry as marketing, advertising, and promotion, there is still little study in terms of understanding how to use sensory marketing as a strategic perspective, especially in the tourism industry.

The results of considering the collected direct relationships show that the sense of smell and sound have no impact on brand image in Ha Giang. First, about the smell element: this factor refers to the natural scent in Ha Giang, the atmosphere here, the scent of public services, and the smell of food and drink here. The authors have found that the above smell factor does not impress tourists and it does not create the tourism brand of Ha Giang. Or it can be said that the scent of Ha Giang is not specific and

different enough to make tourists think about it when they come to Ha Giang. Next, the sound factors mentioned include natural sounds in Ha Giang (sounds of streams, birdsong...), noise or quiet, and music of local identity. In the process of considering their influence on the brand image of Ha Giang, these factors were rejected. This can be explained by the fact that Ha Giang has not yet shown a distinct musical identity that impresses tourists, and noise or quiet is not a concern for tourists to Ha Giang.

Regarding the direct relationship between sensory marketing and tourists' intention to return to Ha Giang, it can be seen that all 5 factors of sensory marketing do not affect the intention to return to Ha Giang for tourists. These factors are indirectly affected by brand image and tourist satisfaction. This can be explained by sensory marketing factors that are the first impression tourists have when coming to Ha Giang through their senses, but this initial impression can leave an impression with tourists but does not urge them to return to Ha Giang. Because tourism is considered to be the process of discovering new places for tourists to return to a tourist destination, it is necessary to build a good brand image to create tourist satisfaction and stimulate the return of tourists.

The visual element in sensory marketing has a positive influence on the Ha Giang brand image, which proves that tourists are attracted to the landscape of Ha Giang tourism. This result is

consistent with the reality of tourism in Ha Giang province because this place has many beautiful scenes that attract tourists every year, such as peach blossom, northwest spring apricot flower, and red rice flower. At the end of March, the buckwheat flower forest, the beautiful scenery of Hoang Su Phi, the rocky plateau of Dong Van, etc. can be experienced. However, this factor does not affect the tourists' intention to return, but the brand image and satisfaction can be explained by the fact that tourism is to experience many places, and every place has beautiful scenery, so beautiful scenery is not only found in Ha Giang, and that is not the core reason for tourists to return to Ha Giang.

The touch factor in sensory marketing has a direct influence on the brand image in Ha Giang, which is explained by the fact that Ha Giang has 22 ethnic groups, so comfortable and close contact between different people of different ethnic groups is very important. In addition, the design of restaurants, cafes, and convenient services for guests is also an important factor, as are the unique souvenir products of Ha Giang. It also creates associations of Ha Giang's brand image in the minds of tourists. Besides, the tactile factor also plays a positive role in considering the specific indirect relationship, the tactile relationship, brand image, and satisfaction, which is the only factor that is accepted when examining the indirect relationship between sensory marketing, brand image, and tourist satisfaction and the intention to return. This result clearly confirms the importance of the tactile factor for tourism in Ha Giang province.

The taste factor in sensory marketing appears only in a direct relationship with the Ha Giang brand image, which can identify Ha Giang cuisine as creating a distinct brand of Ha Giang. At the same time, this factor also affects the relationship between taste, brand image, and tourist satisfaction. This proves that Ha Giang cuisine plays an important role in creating satisfaction, thereby stimulating tourists to return. This is true compared to reality because

Ha Giang cuisine is especially diverse and rich. The positive relationship between brand image, tourist satisfaction, and intention to return to tourism in Ha Giang province is completely true compared to the theoretical basis and practical significance given.

For the theoretical implication of study, from the innovation of sensory marketing activities of the OECD innovation model, the research aims to innovate the marketing activities of Ha Giang to develop local tourism by researching and synthesizing the theoretical basis and proposed analytical framework for sensory marketing and brand image, customer satisfaction and intention to return.

As far as limitations are concerned, due to the actual situation, the study could only conduct an online survey of individuals who have experienced Ha Giang tourism, and at the same time we had no conditions for field research in Ha Giang. In addition, the survey time was not really long and the sample did not have a balanced ratio in terms of gender, income, age, marital status and frequency of travel, etc., so there are limitations on the generality of the study. Due to limited time and resources, the author could only collect observable variables. This is the reason that there are many variables that could not be included in the research model and this led to the research model not being able to explain the most accurately compared to reality.

For future research, authors can expand the sensory marketing studies of many other tourist destinations or other service industries such as restaurant services, hotel services and travel accommodation services. Future research can be conducted in the field at facilities and localities within the study area to get the most accurate sample number.

6. Conclusion

From the innovation element of sensory marketing activities in the OECD innovation model, research towards the innovation of

marketing activities of Ha Giang was conducted in order to develop local tourism by researching and synthesizing the theoretical basis and proposed an analytical framework for sensory marketing and brand image, customer satisfaction and intention to return. The study provides appropriate solutions and implications to innovate Ha Giang tourism on the basis of sensory marketing from improving local brand image and enhancing visitor satisfaction to contributing to creating a desire to go back to Ha Giang. This is also a useful reference for tourism people in Ha Giang towards innovation in tourism here. Besides, the research builds a new research analysis framework that includes all four factors: Sensory Marketing, Brand Image, Visitor Satisfaction, and Return Intention, and analyzes the relationship of the customers. That factor in the innovation of marketing activities in the tourism industry is specifically Ha Giang tourism. This suggests a concept that is relatively little researched in Vietnam today, and that is: sensory marketing associated with innovation and at the same time, applying the OECD innovation model in implementing sensory marketing activities that are geared towards developing destination tourism in Ha Giang. The present study faced constraints in terms of time, resources and the availability of data. Nevertheless, the study recommends certain measures related to future research in order to innovate tourism through sensory marketing activities.

References

- Aaker, D. A. (1996). Measuring brand equity across products and markets. *California Management Review*, 38(3), 102–120.
- Ajzen, L. (1991). The theory of planned behavior. *Organizational Behavior and Human Decision Process*, 50, 179–211.
- Bloemer, J.M.M., de Ruyter, K. & Pascal, P. (1998). Investigating drivers of loyalty: the complex relationship between image, service quality and satisfaction. *International Journal of Bank Marketing*, 16 (7), 276-286.
- Divisekera, S., & Nguyen, V. K. (2018). Determinants of innovation in tourism evidence from Australia. *Tourism Management*, 67, 157-167.
- Fishbein, M. and Manfredo, M. J (1992). A theory of behavior change. In *Influencing human behavior: Theory and applications in recreation, tourism, and natural resource management*, Edited by: Manfredo, M. J. 29–50. Champaign, Illinois: Sagamore Publishing.
- Fornell, C., & Larcker, D. F. (1981). Evaluating structural equation models with unobservable variables and measurement error. *Journal of Marketing Research*, 18(1), 39-50.
- Ghorbanzadeh, D., Shabbir, M. S., Mahmood, A., & Kazemi, E. (2021). Investigating the role of experience quality in predicting destination image, perceived value, satisfaction, and behavioral intentions: a case of war tourism. *Current Issues in Tourism*, 24(21), 3090-3106.
- Giao, H. N. K., & Ngan, N. T. K. (2021). Tác động của hình ảnh điểm đến tới ý định quay lại của khách du lịch nội địa tại Bà Rịa–Vũng Tàu. *SSRN Electronic Journal*, 8, 1 -15.
- Hair, J. F., Black, W. C., Babin, B. J., & Anderson, R. E. (2010). *Multivariate data analysis*. 7th Englewood Cliffs, NJ: Prentice Hall.
- Hair, J. F., Ringle, C. M., & Sarstedt, M. (2011). PLS-SEM: Indeed a silver bullet. *Journal of Marketing theory and Practice*, 19(2), 139-152.
- Hair, J. F., Ringle, C. M., & Sarstedt, M. (2011). PLS-SEM: Indeed a silver bullet. *Journal of Marketing theory and Practice*, 19(2), 139-152.
- Jang, H. W., & Lee, S. B. (2019). Applying effective sensory marketing to sustainable coffee shop business management. *Sustainability*, 11(22), 6430.
- Jung, J., Kim, S. J., & Kim, K. H. (2020). Sustainable marketing activities of traditional fashion market and brand loyalty. *Journal of Business Research*, 120, 294-301.
- Kim, W. H., Lee, S. H., & Kim, K. S. (2020). Effects of sensory marketing on customer satisfaction and revisit intention in the hotel industry: the moderating roles of customers' prior experience and gender. *International Journal of Tourism and Hospitality Research*, 31(4), 523-535.
- Kofler, I., Marcher, A., Volgger, M., & Pechlaner, H. (2018). The special characteristics of tourism innovation networks: the case of the Regional Innovation System in South Tyrol. *Journal of hospitality and tourism management*, 37, 68-75.
- Mohammed, A., & Rashid, B. (2018). A conceptual model of corporate social responsibility dimensions, brand

- image, and customer satisfaction in Malaysian hotel industry. *Kasetsart Journal of social sciences*, 39(2), 358-364.
- Moreira, A. , Fortes, N. , & Santiago, R. (2017). Influence of sensory stimuli on brand experience, brand equity and purchase intention. *Journal of Business Economics and Management* , 18(1), 68–83.
- Nadanyiova, M., Kliestikova, J., & Kolencik, J. (2018). Sensory marketing from the perspective of a support tool for building brand value. *Economics and Culture*, 15(1), 96-104.
- OECD. (2005). *ICT, e-business and SMEs. OECD digital economy papers*, No. 88. Paris: OECD Publishing
- OECD. (2013). *Green innovation in tourism services, OECD tourism papers*, 2013/01. Paris: OECD Publishing.
- Petit, O., Velasco, C., & Spence, C. (2019). Digital sensory marketing: Integrating new technologies into multisensory online experience. *Journal of Interactive Marketing*, 45, 42-61.
- Rather, R. A. (2018a). Investigating the impact of customer brand identification on hospitality brand loyalty: A social identity perspective. *Journal of Hospitality Marketing & Management*, 27(5), 487–513.
- Rather, R. A. (2018b). Exploring customers' attitudes towards the hospitality brands in India: A social identity perspective. In *The Branding of Tourist Destinations, Theoretical and Empirical Insights* (pp. 211–231).
- Ryu, K., Han, H., & Kim, T. H. (2008). The relationships among overall quick-casual restaurant image, perceived value, customer satisfaction, and behavioral intentions. *International Journal of Hospitality Management*, 27(3), 459-469.