

Study, Design and Manufacture Microstrip Antenna For Advance Mobile Handsets

Tran Minh Tuan*

National Institute of Information and Communications Strategy, 115 Tran Duy Hung, Hanoi, Vietnam

Received 19 March 2010

Abstract. This paper concentrates on studying, designing and manufacturing a dual – band and high – bandwidth antenna applied for advance mobile handsets. This antenna can work in GSM/UMTS bands by generating two resonant modes of 900 MHz and 1900 MHz frequencies. Antenna is printed on FR4 substrate with size of 58 mm x 80 mm, thickness of 1.6 mm and relative permittivity of 4.4. The propose antenna is experimentally studied.

Keywords: Antenna, dual-band, monopole, microstrip antenna.

1. Introduction

Nowadays, 3G mobile terminals are gaining immense popularity thank to their advanced and user-friendly features. Therefore, designing new compact antennas with good characteristics, easy to manufacture and low cost applied for advance mobile terminals is quite necessary although number of similar studies had been conducted so far [1-4].

In this paper, this antenna is chosen because it has advantages by its characteristics such as easier to design and manufacture than the PIFA antennas.

Thank to simple structure and omni-directional radiation, monopole antennas have been found widespread applications in mobile communication systems. To meet the miniaturization of modern mobile

communication equipments, the design of compact monopole antennas is of particularly importance. In this paper, a simple way has been proposed where a meandering conductor line printed on a dielectric substrate is used to reduce the size of a monopole antenna. But the resulted antenna was mainly applicable for single-band operation. To achieve dual-band operation in a compact monopole antenna design, we propose a novel design of monopole antenna by extending conductor lines from rectangular meander monopole. The proposed antenna is fed by a 50 Ohm SMA connector. This antenna can be manufactured by simple procedure. Moreover, thank to the presence of extended conductor lines in the proposed design, antenna is not only capable of providing the GSM/UMTS dual-frequency operations, but also can have small antenna-size.

* Tel.: 84-4-35565043.

E-mail: tm_tuan@mic.gov.vn

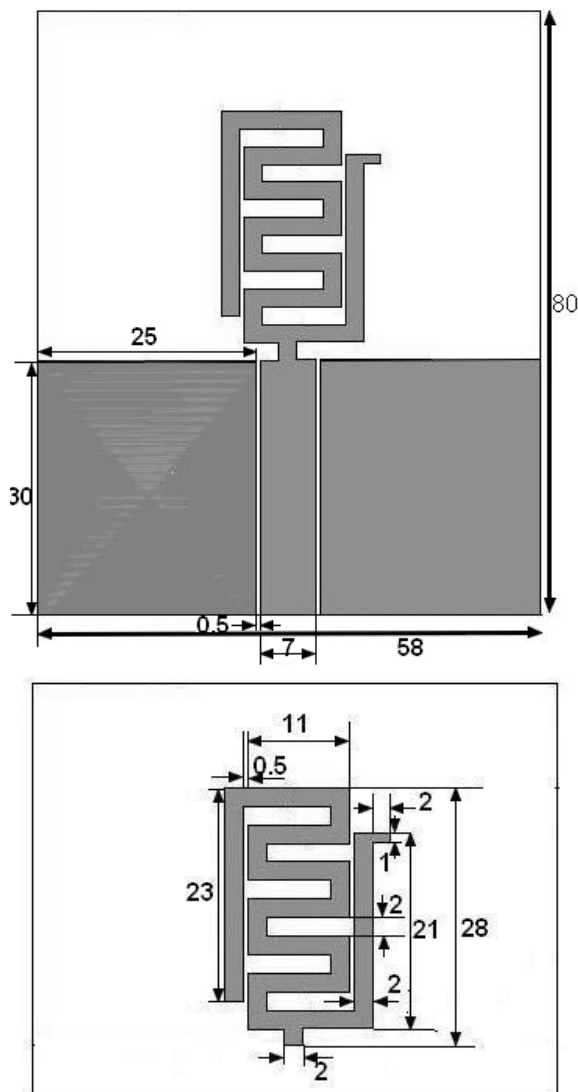

Fig. 1. Overview the antenna.

2. Designing antenna and simulation results

Fig. 1 shows an overview of the antenna. Antenna is printed on an FR4 substrate which size is 58 mm x 80 mm with thickness of 1.6 mm and relative permittivity of 4.4.

The antenna consists of a $1/4$ wavelength vertical element over a solid sheet or radial wire ground plane with diameter of $1/4$ wavelength.

The basis of the antenna structure is a rectangular meander monopole, which has the dimensions of height 28 mm and width 11 mm. The conductor line of height 23 mm is extended from the end of the rectangular meander monopole at the left-hand side and other conductor line of height 21 mm is extended from the starting of the rectangular meander monopole at the right-hand side. These extended conductor lines are located relatively close to the rectangular meander monopole. The space between the two conductors is 0.5 mm. In this design, the extended conductor line increases the current path of the antenna's first resonant mode, which reduces the required size of the proposed antenna for a fixed operating frequency.

Moreover, as the conductors are close to each other, the electromagnetic 2 coupling is created between the conductors, which leads to the second resonant mode excited with good impedance matching. That is, by introducing the extended conductor line, the proposed compact dual-frequency monopole antenna with good impedance matching can be obtained [5].

In addition, there are 2 ground planes are put on the only layer with the antenna, each one's size is 25mm x 30 mm. By placing 2 ground planes and radiator of the antenna in a layer together, ground plane acts like a mirror, to reflect a ghost image of it. That way it will act like a half wavelength antenna, but only be a quarter wavelengths long [6]. And there are 2 pieces of copper are using to connect the layer that containing the antenna with a part of other layer of the FR4 substrate which its size is 58mm x 3 mm. It makes the antenna likely to be fed by a CPW connector although a 50 Ohm SMA connector is used to feed the antenna.

The simulation is carried out by Ansoft HFSS 11 software. Figure 2 shows the result for S11 of antenna.

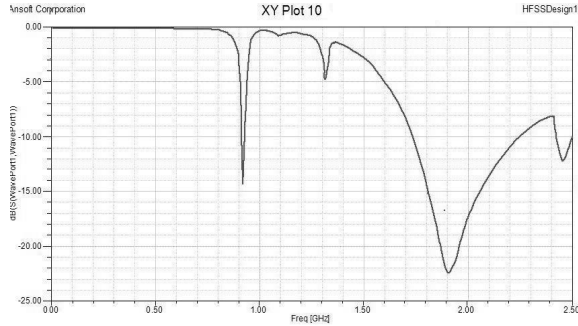
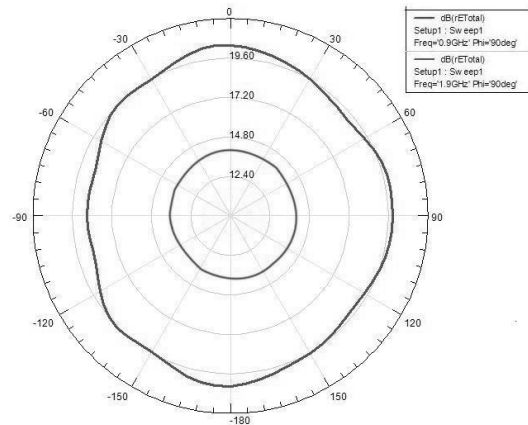

Fig. 2. S11 parameter (dB).

As shown in fig. 2, two resonant modes are excited at 910 and 1900 MHz simultaneously with good impedance matching. The 10-dB return-loss bandwidth at the lower frequency is 52 MHz (882 - 934 MHz). And the bandwidth at the upper frequency reaches to 521 MHz (1724 - 2245 MHz). Obviously, the obtained bandwidths cover both the GSM/UMTS bands.



(c) YOZ plane

Fig. 3. 2D Radiation patterns.

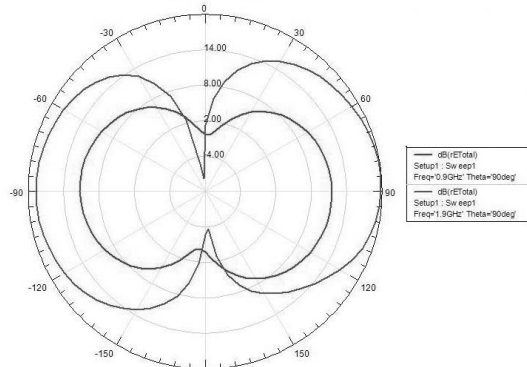

(a) XOY plane

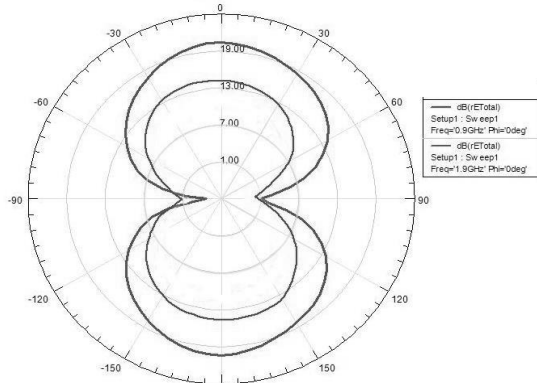

(b) XOZ plane

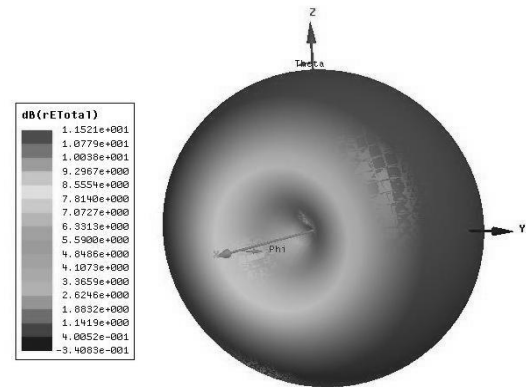

(a) 900 MHz

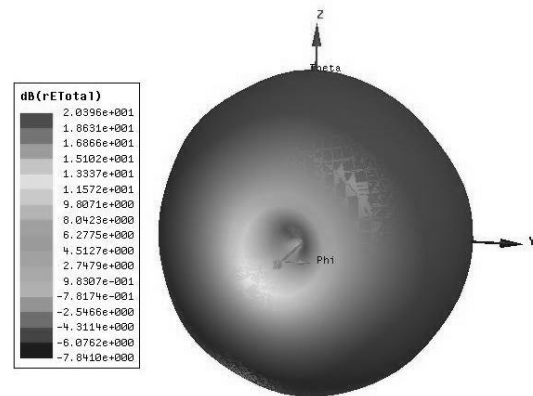

(b) 1900 MHz

Fig. 4. 3D Radiation patterns.

3. Measurement result

Fig. 5 shows measurement result for return loss. Bringing it to compare with the simulation, we have a comparison shown in Fig. 6.

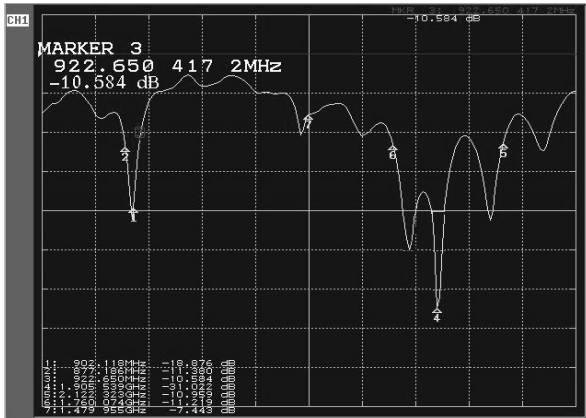

Fig. 5. The measurement result.

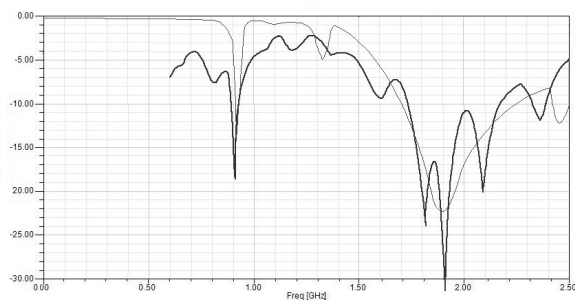

Fig. 6. Comparison between the simulation and measurement.

Prototypes of the proposed antenna were constructed and tested. Good agreement between the measurement and simulation is obtained. Two resonant modes at about 900 and 1900 MHz are successfully excited. The lower resonant mode shown an impedance bandwidth of 45 MHz (877 ~ 922), which covers most of required bandwidth of the GSM system. For the upper resonant mode, it has an impedance bandwidth of 362 MHz (1760 ~ 2122) which also cover all required bandwidth of the DCS system.

The last figure shows real antenna that we did.

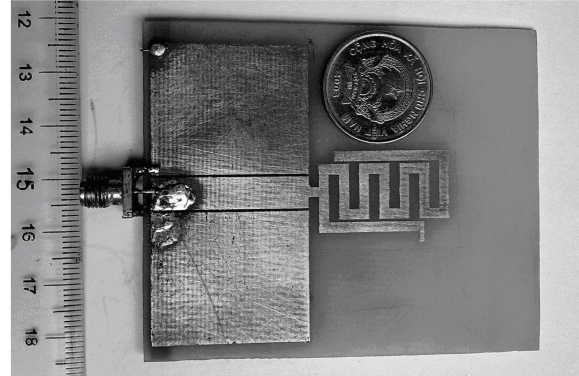

Fig. 7. The real antenna.

4. Conclusion

The designed antenna suitable for GSM/UMTS operation in an advance mobile handsets has been demonstrated. The return loss bandwidths of the lower and upper modes of the proposed antenna cover the required bandwidths of the GSM/UMTS systems. The proposed antenna is especially suited for application in 3G mobile handsets.

Acknowledgements

This work is supported in part by Korea advanced institute of science and technology – Information Communications College (KAIST ICC) of Korea.

References

- [1] Peter Lindberg and Erik Ojefors, "A bandwidth enhancement technique for mobile handset antennas using wavetraps", 2006 *IEEE*, vol.54, pp.2226-2233, August 2006.
- [2] Jerzy Guterman, António A. Moreira, and Custódio Peixeiro, "Microstrip fractal antennas for multistandard terminals", 2004 *IEEE*, vol.3, pp.351-354, 2004.

- [3] Kin-Lu Wong, Yuan-Chih Lin, and Ting-Chih Tseng, "Thin internal GSM/DCS patch antenna for a portable mobile terminal", 2006 *IEEE*, vol.54, pp.238-242, January 2006.
- [4] P.Nepa, G.Manara, A.A.Serra, and G.Nenna, "Multiband PIFA for WLAN mobile terminal", 2005 *IEEE*, vol.4, pp.349-350, 2005.
- [5] Phan Anh, "Antenna Theory and Technique", Science and Technical Press, Hanoi 2000.
- [6] David M. Pozar, *Microwave Engineering*, John Wiley & Sons, INC, Second Edition.

Nghiên cứu, thiết kế và chế tạo anten mạch dải đa băng cho các đầu cuối di động thế hệ mới

Trần Minh Tuấn

*Viện Chiến lược Thông tin và Truyền thông, Bộ Thông tin và Truyền thông,
115 Trần Duy Hưng, Hà Nội, Việt Nam*

Bài báo tập trung vào việc nghiên cứu, thiết kế và chế tạo một anten đa băng và băng rộng ứng dụng cho thiết bị di động thế hệ mới. Anten này có thể hoạt động ở băng GSM/UTMS do nó có hai tần số cộng hưởng là 900 MHz và 1900 MHz. Anten được chế tạo trên tấm FR-4 với kích thước 58 mm x 80 mm, độ dày 1.6 mm và hằng số điện môi là 4.4. Mẫu anten này đưa ra nhằm cho mục đích nghiên cứu, chế tạo thử nghiệm.